

# GO2cam

cam for workshops

GO2cam is a comprehensive high-end CAM solution for milling, turning and wire EDM.

## GO2Cam's Milling Software



**GO2cam Mill is a CAM for 2-5 axis milling, combining power and ease of use.**

GO2cam International was founded in 2009, by a pioneer team in CAM software development. **Our mission is to provide specific CAM solutions to simplify the NC programming.**

GO2cam International offers mechanical solutions designed with same guidelines that make our success in other markets: **innovation, accessibility and R&D reactivity.**

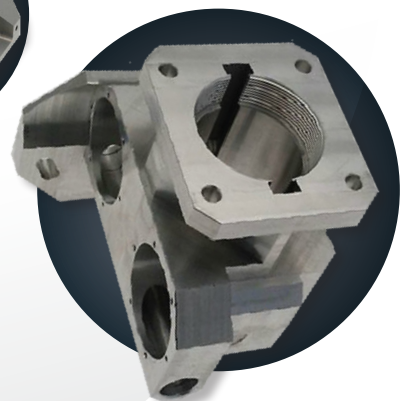

# GO2Cam's Milling Software

## Technical characteristics

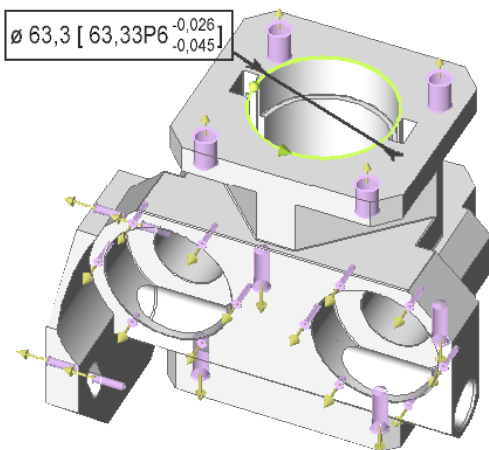

### → CAD

- Open native CAD files
- Holes
- Topology
- Tolerancing
- Parametric functions Wireframe and Solid

### → CAM

- Milling 2X-5X simultaneous
- Save expertise (operation list, tools)
- Stock management
- Time calculation
- Machine-tool environment (MTE) simulation
- Workshop documents: pdf, xls

### → 2X

- Facing / Pocket / Contouring / Drilling
- HSM
- Plunge cutting
- Reworking cycles

### → 3X

- Roughing
- Rework roughing
- Finishing
- Finish rework

### → 4Xs & 5Xs

- Roughing
- Sweeping machining
- Swarf machining

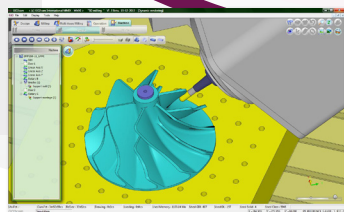

**GO2cam**  
INTERNATIONAL

6 Place des Terreaux 69001 Lyon - France  
+33 4 72 27 06 64 ▪ sales@go2cam.net

[www.go2cam.net](http://www.go2cam.net)